



深圳市科源信科技有限公司  
Shenzhen KeYuanXin Technology CO.,LTD

# 产品规格书

**SPECIFICATION FOR APPROVAL**

深圳市福田区振华路 118 号华丽装饰一栋西座 306A  
306A Block West Building 1, Huali Decoration  
NO.118 Zhenhua Road Futian District Shenzhen  
电话 TEL: 4008-735-535 传真 FAX: 0755-23616323



Product Name:

Crystal

---

Product Type:

SMD 5032

---

Nominal Freq:

27.1200MHz

---

ProvideBrand:

KKST

---

P/N:

KAG27120H03R

---

Customer P/N:

---

Approved By Customer

Signature: \_\_\_\_\_

Date: \_\_\_\_\_



## **CONTENT**

**NO.1 Product specification and features**

**NO.2 Product outline dimension**

**NO.3 Product reliability**

**NO.4 Package specification**



## N0.1 Product specification and features

<b>1.1 General characteristics</b>	
Nominal frequency	27.120000 MHz
Overtone order	Fundamental
Type	SMD 5032
Operating temperature	-20~70 °C
Storage temperature	-40~85 °C
<b>1.2 Electric characteristics</b>	
Adjustment tolerance: (at+25°C)	±20 ppm
Tolerance over the temperature:	±20 ppm
Load capacitance	20.0 pF
Drive level	100.0 μW
Equivalent resistance	60.0 Ω Max
Shut capacitance	7.0pF Max
Insulation resistance	500 M Ω Min 100VDC ± 15VDC
Aging	±3ppm/Year
<b>1.3 Other characteristics</b>	
SPDB	<-3 dB

## NO.2 Outline dimensions、Appearances

### 2.1 Product outline dimension(mm)

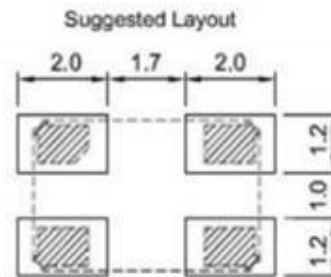
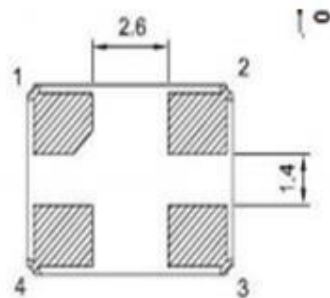
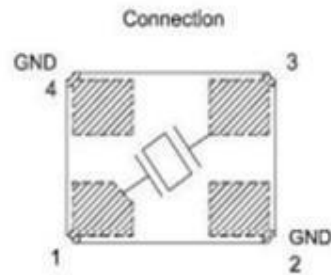
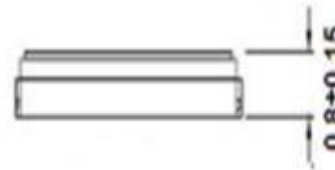
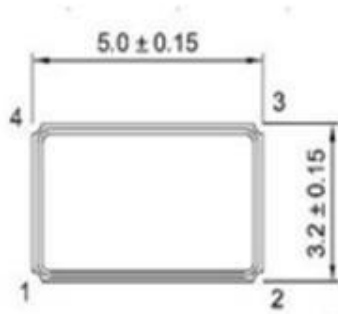

2.2 Carrier Dimensional Drawing (mm)

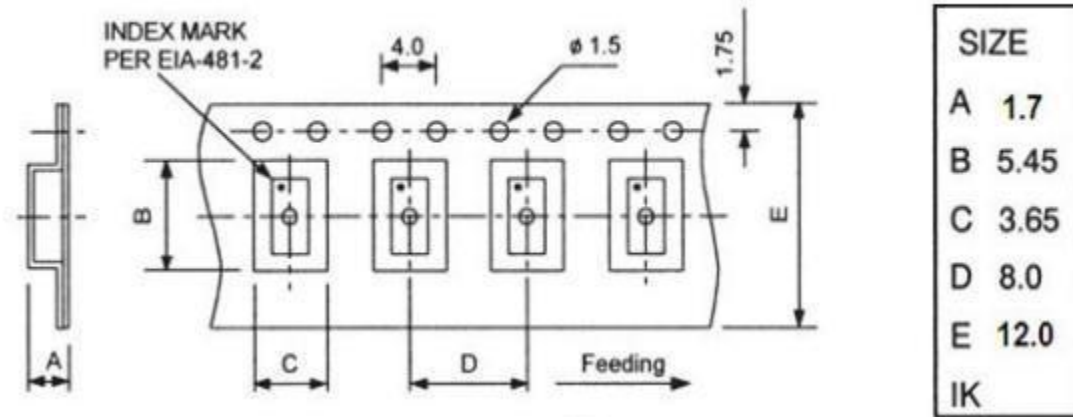

2.3 Reel Dimensional Drawing (mm)

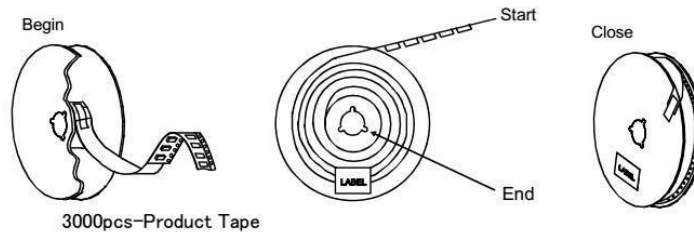
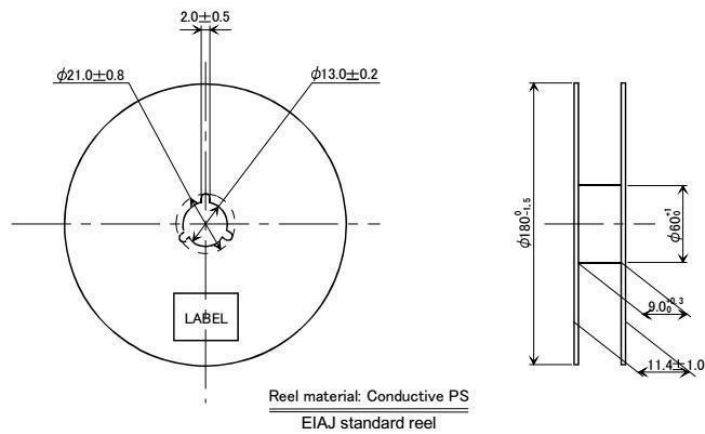

### NO.3 Product reliability

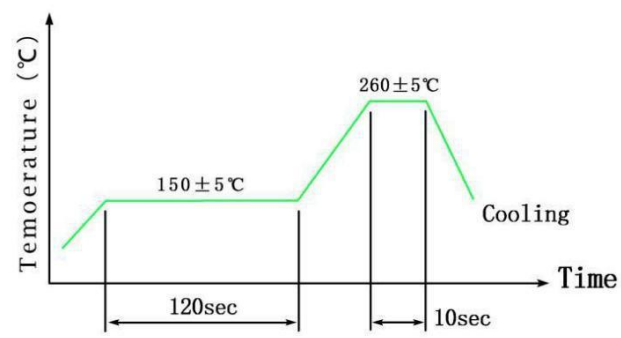
Item	Condition	Result
A1	<b>Cold resistance</b> Stored at $-40\pm 2^{\circ}\text{C}$ for $1000\pm 2$ hrs then $25\pm 2^{\circ}\text{C}$ 1~2 hrs before testing	(I)
A2	<b>Heat resistance</b> Stored at $85\pm 2^{\circ}\text{C}$ for $1000\pm 2$ hrs then $25\pm 2^{\circ}\text{C}$ 1~2 hrs before testing	(I)
A3	<b>Salt Mist Test</b> Spray the $35^{\circ}\text{C}\pm 2^{\circ}\text{C}$ salt water (salt density 5%) to crystal for $48\pm 2$ hrs,then clean by water	(I)
A4	<b>Humidity Resistance Result</b> Steady temperature: $60\pm 2^{\circ}\text{C}$ ;humidity: 90 ~ 95 % RH; time:500h	(I)
A5	<b>Mechanical Shock</b> $14700\text{m}/\text{S}^2$ 0.5sec 5times in each of 6 direction	(I)
A6	<b>Aging</b> Stored at $85\pm 3^{\circ}\text{C}$ for $720\pm 12$ Hrs then $25\pm 2^{\circ}\text{C}$ 1~2 Hrs before testing Stored at $25\pm 2^{\circ}\text{C}$ for $1\pm 0.03$ year	(I)
A7	<b>Leakage</b> Fine leak: Helium leak test *JIS C 6701 10.6	(V)
A8	<p><b>Temperature Cycle</b> <math>-40^{\circ}\text{C} \sim 85^{\circ}\text{C}</math>, Dewell 30Min, 100 cycles</p>  <p>The graph shows Temperature (°C) on the y-axis and Time on the x-axis. The cycle consists of three segments: a ramp up to <math>150\pm 5^{\circ}\text{C}</math>, a dwell at <math>150\pm 5^{\circ}\text{C}</math> for 120sec, a ramp up to <math>260\pm 5^{\circ}\text{C}</math>, a dwell at <math>260\pm 5^{\circ}\text{C}</math> for 10sec, and a cooling ramp. The label 'Cooling' is placed next to the final downward slope.</p>	(I)

3.1 Mechanism characteristics

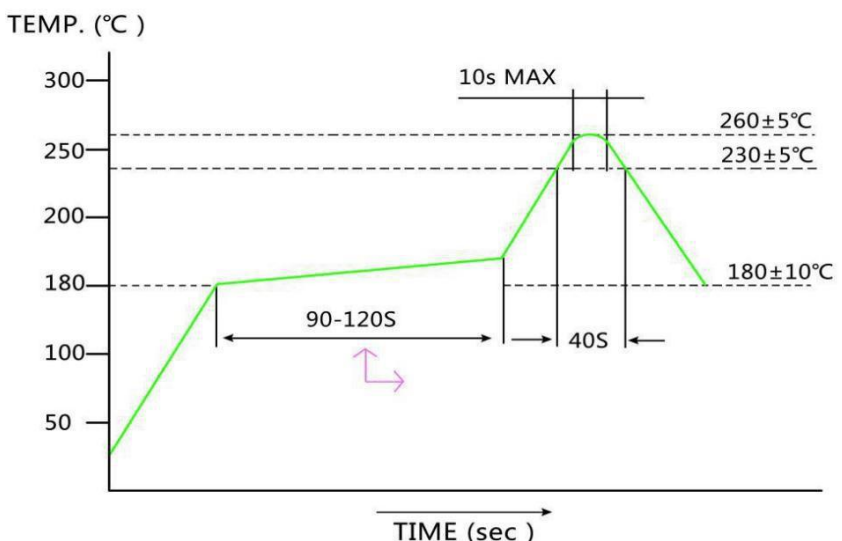
<p><b>B.1</b></p>	<p><b>Drop Test</b> Device are dropped from a height of 100 cm onto 20mm thickness stainless plate executing 3 times of random drops</p>	<p>(I)</p>
<p><b>B.2</b></p>	<p><b>Resistance of Vibration</b> Frequency: 10~55Hz, amplitude(total excursion): 1.5mm±15%,3 direction (X,Y,Z) each 2 hr</p>	<p>(I)</p>
<p><b>B.3</b></p>	<p><b>Resistance to soldering heat (Hand soldering method)</b> Temperature: 370~400°C; Time: 3~4sec; Frequency: 2 times; Soldering iron: 60W/Min</p>	<p>(I)</p>
<p><b>B.4</b></p>	<p><b>Solderability</b> 240±2°C, 3±0.5sec</p>	<p>(II)</p>
<p><b>B.5</b></p>	<p><b>Reflow) Resistance to soldering heat (Reflow)</b> 260± 5°C; 10S; 2Times</p> <p style="text-align: center;">Reflow</p>  <p>The graph shows a reflow temperature profile. The y-axis is labeled 'TEMP. (°C)' with values 50, 100, 180, 200, 250, 300. The x-axis is labeled 'TIME (sec)'. The profile starts at 50°C, rises to 180°C (90-120s), then to a peak of 260±5°C (10s MAX), and finally to 180±10°C (40s). A 230±5°C level is also indicated. A pink arrow points to the 90-120s interval.</p>	<p>(I)</p>





Item	Result NO.	Specification Requirements
1	( I )	Frequency variation $< \pm 10 \text{ppm}$ Resistance variation $< 5 \Omega$ or 15% of RR spec., select the bigger value
2	( II )	The covering rate of Tin-plating is more than 95%
3	( III )	There is no bubbles after the Crystal is dipped in the water Insulation Resistance: $500 \text{ M}\Omega$ Min $100 \text{VDC} / \pm 15 \text{VDC}$
4	( IV )	The Crystal is no crackle under the observation of 10 times Magnifier.
5	( V )	$1 * 10^{-9} \text{Pa.m}^3/\text{s}$ Max

## NO.4 Package specification

### 4.1 Marking



### 4.2 Label

KST KEYUANXIN TECHNOLOGY GO.,LTD		
Item	Crystal	QTY: 1000PCS
P/N	KAG27120H03R	
FREQUENCY	27.120MHz	DATE: 2018-03-12
		

### 4.3 Package specification

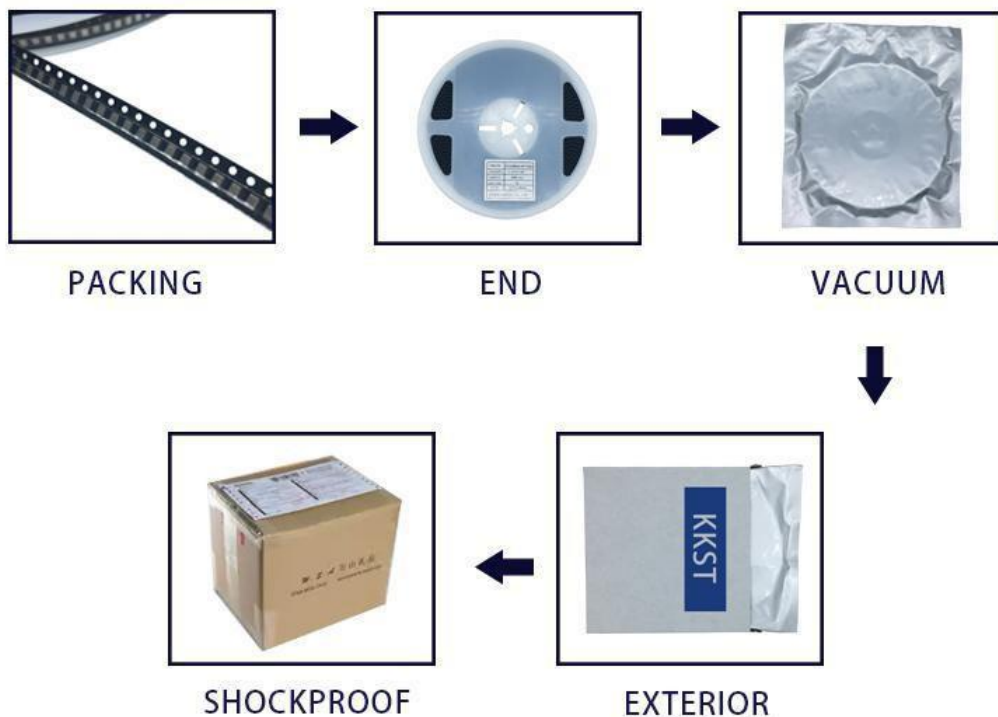



KEYUANXIN TECHNOLOGY GO.,LTD

浏览网址：[www.szkyx.cn](http://www.szkyx.cn)