



深圳市科源信科技有限公司
Shenzhen KeYuanXin Technology CO., LTD

产品规格书

SPECIFICATION FOR APPROVAL

深圳市福田区振华路 118 号华丽装饰一栋西座 306A
306A Block West Building 1, Huali Decoration
NO.118 Zhenhua Road Futian District Shenzhen
电话 TEL: 4008-735-535 传真 FAX: 0755-23616323



Product Name: Crystal

Product Type: SMD 2520

Nominal Freq: 26.0000MHz

ProvideBrand: PARTRON



P/N: CXC5X260000GJVRR00

Customer P/N: _____

Approved By Customer

Signature: _____ **Date:** _____

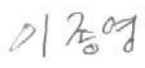
APPROVAL SHEET

PRODUCT NAME	SMD CRYSTAL UNIT		
USER NAME	LG이노텍		
USER PART NO.	20SC00056A		
Provider	PARTRON		
PARTRON MODEL	CXC6X260000GJVRR00		
CUSTOMER	Issued by	Checked by	Approved by
PARTRON	Issued by	Checked by	Approved by
			
In Charge	L.J.Y.	M.N.S.	K.J.M.
Division	R & D	Q C	R & D

MSL	LEAD FREE	Halogen-Free
MSL LEVEL 1		

	Case
Fab	China/Yantai/Partron
Assembly	China/Yantai/Partron
Final Test & Packing	China/Yantai/Partron

※ Please return one copy with approval to PARTRON

2014. 10. 05

22-6, Seokwoo-dong, Hwaseong-si, Gyeonggi-do, Korea 445-170
TEL : 82-31-201-7750

Contents

1. Revision History	- - - 3
2. Electrical characteristics	- - - 4
3. Mechanical characteristics	- - - 6
4. A Primary test result	- - - 7
5. Reliability test	- - - 8
6. Soldering Condition	- - - 11
7. Construction	- - - 12
8. Notices	- - - 13
9. Packing	- - - 14

1. Revision History

Rev.	Date	Rev.page	Revision Content and Reason	Remark
V1.0	'14.10.05	All Page	First-edition	

2. Electrical Characteristics

No.	Item	Symbol	Content
2.1	Frequency	f_0	26.0000 MHz
2.2	Frequency Tolerance 	$\Delta f/f_0$	± 10 ppm (@+25°C $\pm 2^\circ\text{C}$)
2.3	Temperature range	Storage	T_{STG} -40 to 100°C
		Operating	T_{OPR} -20 to 100°C
2.4	Frequency stability	$\Delta f/f_0$	± 10 ppm (-20°C to +85°C) ± 30 ppm (+85°C to +100°C)
2.5	Drive level	DL	200 uW max.
2.6	Equivalent series resistance	R1	60 Ω max.
2.7	Oscillation mode	O/T	Fundamental
2.8	Shunt capacitance	CO	3 pF max.
2.9	Motional capacitance	C1	10 fF max.
2.10	Load capacitance	C_L	8.0 pF
2.11	Aging	fa	± 3 ppm/3year max. (@+25°C $\pm 2^\circ\text{C}$)
2.12	DLD2 (0.01uW~100uW 20step)	DLD2	15 Ω max
2.13	RLD2 (0.01uW~100uW 20step)	RLD2	60 Ω Max
2.14	Insulation resistance	IR	500 M Ω min @ 100VDC

[REMARK]

* Note 1

- Blank sorting 방법은 QC 공정도에 첨부됩니다.

2-1 Crystal Equivalent Circuit and Application Circuit

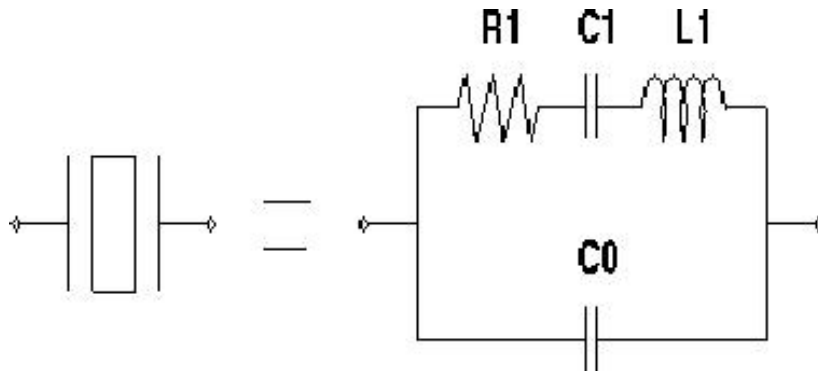

[Crystal and equivalent circuit]

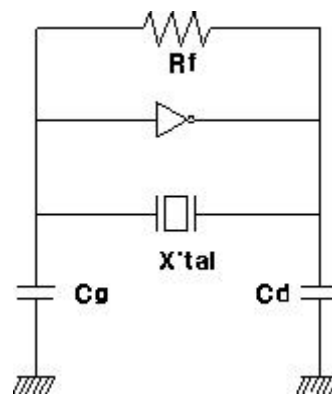

[Application circuit for oscillation]

3. Mechanical characteristics

3-1 Outline Dimensions and Pin connections

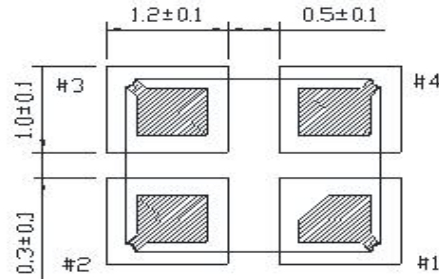
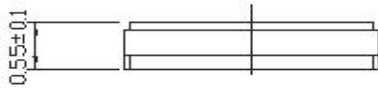
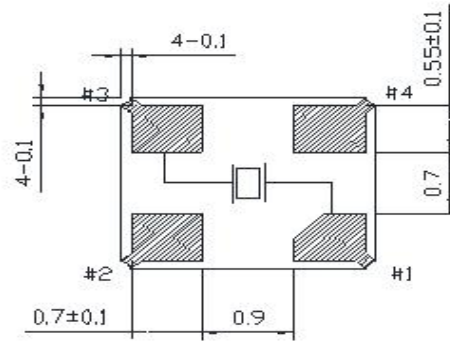
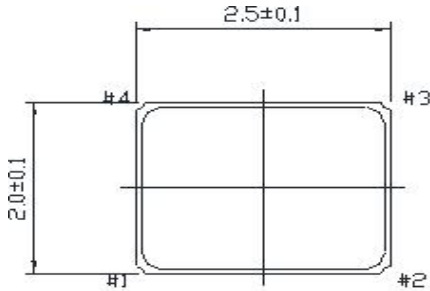

[Recommended solder pad layout]

Pin connections	
#1	HOT
#2	GND
#3	HOT
#4	GND

3-2 Marking and LOT No

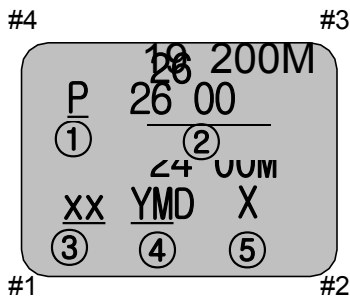

※ Laser Marking

ITEM	MARKING	REMARK
①	P	Partron logo
②	26 00	Frequency: 26.0000MHz
③	xx	CRYSTAL CL 1 digit : ※ Note 1 참조 2 digit : 소수점 자리 ※ 소수점 적용 여부에 따라 1 or 2 digit로 표기함. EX) C5=12.5pF, R=8pF
④	YMD	Y : the last 1 digit of year 1 to 9, A to V (A=10, V=31) M : 1 digit of month (Jan to Sept; 1 to 9, Oct; A, Nov B, Dec; C) D : 1 digit of day 1 to 9, A to V (A=10, V=31) EX) E6N = 2014.06.23, E88 = 2014.08.08
⑤	X	Internal Code

* Note 1

1 Digit	S	T	R	N	B	P	C	Q	D	E	F	G	H
Crystal CL	6pF	7pF	8pF	9pF	10pF	11pF	12pF	13pF	14pF	15pF	16pF	18pF	20pF

4. A Primary test result

Electrical Characteristics Testing Data

No.	Item	Result	FL (ppm)	C0 (pF)	RR (Ω)	C1 (fF)	L (mH)	TS (ppm/pF)	DLD2 (Ω)	RLD2 (Ω)
Spec	High		10.0	3.0	60.0	10.0	-	-	15.00	60.00
	Low		-10.0	-	-	-	-	-	-	
Max	Pass		-1.9	1.2	21.1	3.7	10.6	21.5	0.5	21.2
Min	Pass		-5.8	1.2	8.2	3.5	10.3	20.8	0.2	8.3
Average	Pass		-3.2	1.2	13.2	3.6	10.4	21.1	0.3	13.3
Stdev	Pass		1.4	0.0	4.2	0.0	0.1	0.2	0.1	4.2
1	Pass		-1.9	1.2	10.7	3.6	10.4	21.2	0.2	10.7
2	Pass		-2.2	1.2	18.7	3.6	10.3	21.5	0.5	18.8
3	Pass		-2.5	1.2	21.1	3.6	10.3	21.3	0.5	21.2
4	Pass		-4.5	1.2	12.7	3.6	10.4	21.2	0.2	12.7
5	Pass		-1.9	1.2	11.5	3.6	10.4	21.1	0.4	11.7
6	Pass		-2.9	1.2	11.9	3.6	10.5	21.0	0.3	12.1
7	Pass		-2.3	1.2	10.5	3.5	10.6	20.8	0.2	10.6
8	Pass		-5.0	1.2	16.6	3.7	10.3	21.5	0.3	16.8
9	Pass		-5.8	1.2	8.2	3.6	10.4	21.2	0.2	8.3
10	Pass		-3.6	1.2	10.3	3.6	10.5	20.8	0.3	10.4

5. Reliability test

5.1 Environment Test

Contents	Condition	Remark
High temperature Storage	+125°C±5°C, 240 hr	*Testing is complete, leave at room temperature for 24 hours, and Measure.(25°C±5°C) * Be satisfied with contents No 2. Specification
Low temperature Storage	-55°C±5°C, 240 hr	
High temperature High humidity Storage	+85°C±5°C, RH=85%, 96 hr	
PCT	+121°C±5°C, RH=100%, 24hr	

5.2 Thermal shock , Reflow Test

Contents	Condition	Remark
Thermal shock	-40°C±5°C,+90°C±5°C, 15 min, 300 cycle	*Testing is complete, leave at room temperature for 24 hours, and Measure.(25°C±5°C) * Be satisfied with contents No 2. Specification
REFLOW	Pre Heating 200±5°C , 30 ~ 60 sec Peak Heating 260°C±5°C , 30sec Max 3 times	

5.3 Mechanical Test

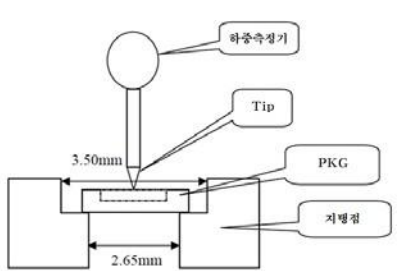
Contents	Condition	Remark
Vibration	Frequency : 10~500Hz, 10 ×9.8 m/s ² (G) Sweep time 15min ,X.Y.Z each 5 times	*Testing is complete, leave at room temperature for 1 hours, and Measure.(25°C±5°C) * Be satisfied with contents No 2. Specification
Drop test	12 times falling at a 160cm height (falling with jig)	
Flexural Strength	Load cell 500N Reflection : 2.5mm C.H.S : 0.5 mm/min 	* >15N

Contents	Condition	Remark
Banding Test	keeping times : 30sec deflection : 3mm 	* Testing is complete, leave at room temperature for 1 hours, and Measure.(25°C±5°C) * Be satisfied with contents No 2. Specification
Shear Test	keeping times : 60sec Static Load : 5Kg 	* >4Kg ※ Note3

5.4 Table

Frequency change permitted	±5ppm Max.
----------------------------	------------

※ Note2

Part Number	2520 Crystal PKG		
Test Measurement	Unit : N		
Test Equipment	IMADA ZP-100N		
Test Limit	> 15N		
1	16.1	11	16.3
2	15.5	12	16.4
3	16.1	13	17.1
4	17.6	14	17.4
5	16.8	15	16.2
6	15.8	16	16.3
7	16.8	17	16.1
8	16.5	18	15.7
9	17.1	19	16.6
10	16.7	20	15.5
Min	15.5		
Max	17.6		
AVE	16.42		
Result	Pass		

※ Note3

	Banding Test		Shear Test	
Test Measurement	Unit : Δ ppm		Unit : Kg	
Test Equipment	PCB Board		DAGE 4000 series	
Test Limit	± 5 ppm		> 4.0 Kg	
1	0.5	Pass	4.852Kg	Pass
2	1.0	Pass	4.91Kg	Pass
3	0.8	Pass	4.885Kg	Pass
4	0.3	Pass	4.812Kg	Pass
5	1.2	Pass	4.828Kg	Pass
6	1.1	Pass	4.922Kg	Pass
7	1.5	Pass	4.911Kg	Pass
8	0.3	Pass	4.879Kg	Pass
9	1.2	Pass	4.896Kg	Pass
10	0.5	Pass	4.912Kg	Pass
Min	+0.3		4.812Kg	
Max	+1.5		4.922Kg	
AVE	+0.84		4.880Kg	
Result	Pass		Pass	

6. Soldering Condition

6.1 Standard Reflow soldering condition

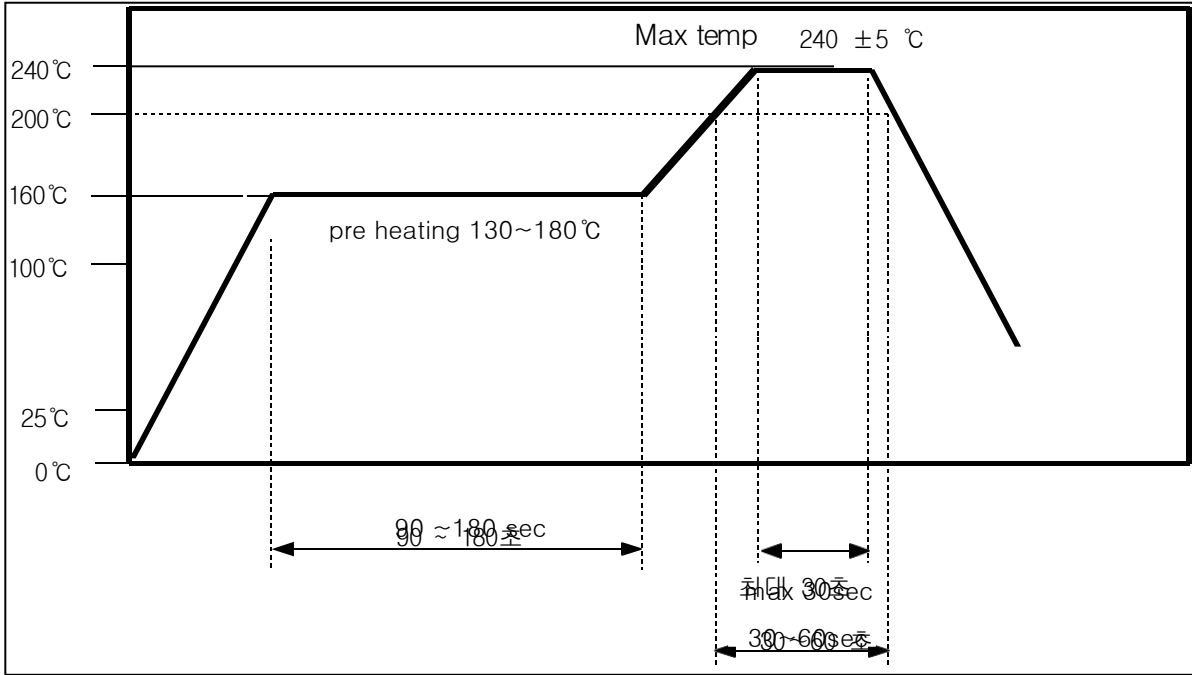

6.2 The maximum temperature guarantees to the 260°C(10sec Max)

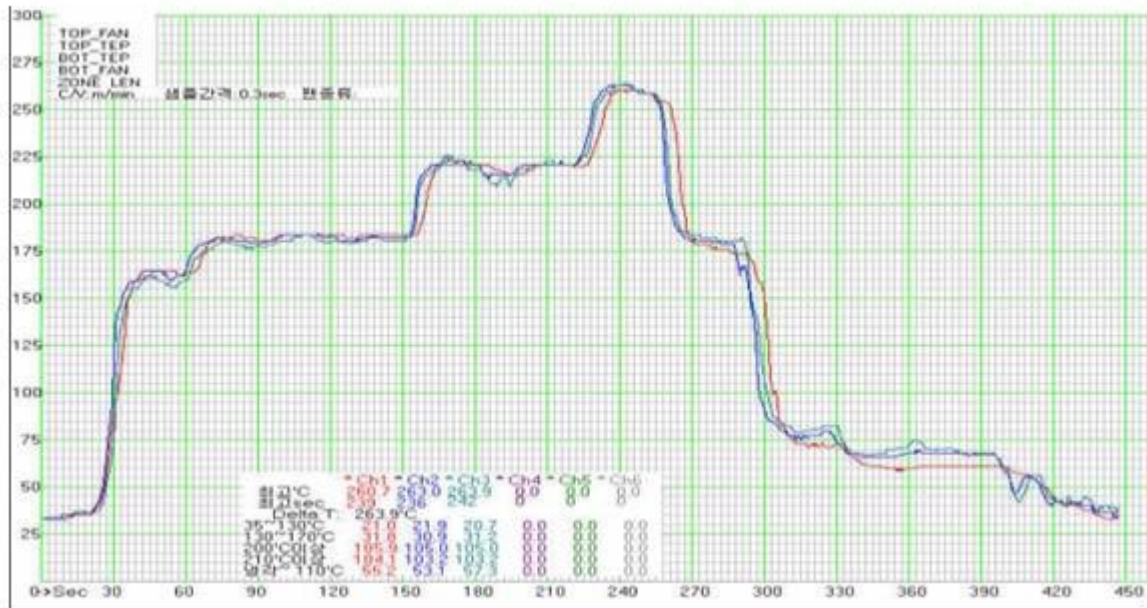

6.3 Soldering Iron Method

- Pre heating : 120°C (30 ~ 300 sec)
- Max temp : 410°C Max
- Time : Max 4 sec

7. Construction

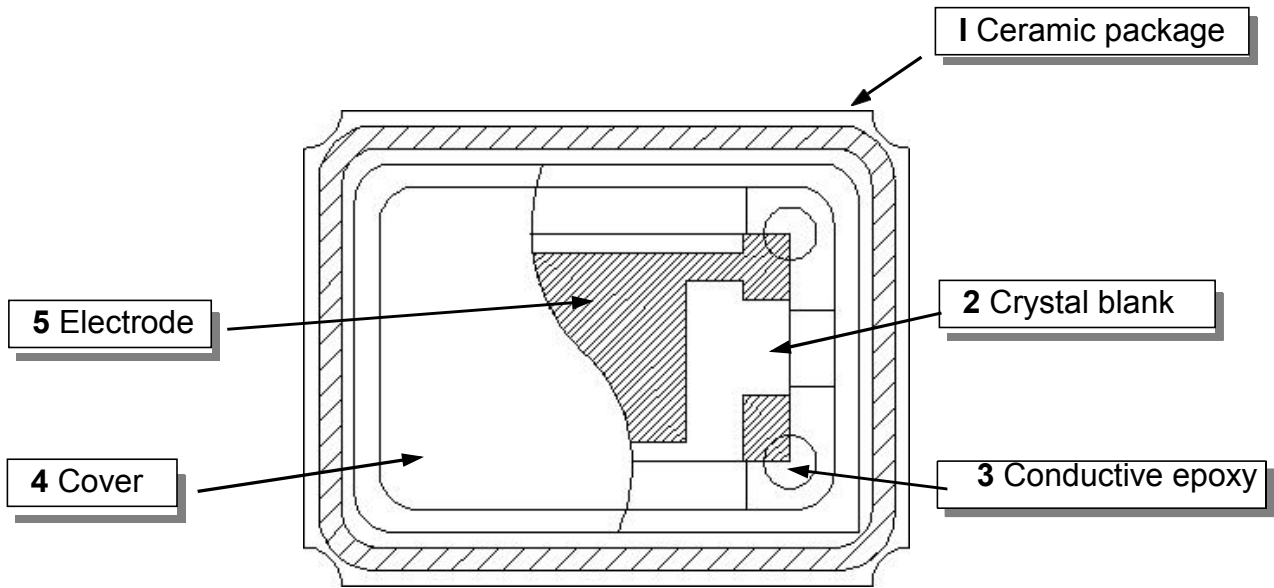

No	item
1	Ceramic package
2	Crystal blank
3	Conductive Epoxy
4	Lid(Cover)
5	Electrode

8. Notices

8-1 Max. two(2) times reflow is allowed.

Once miss soldering is happen, hand work soldering by soldering iron is recommended.
(+400°C x within 5 sec)

8-2 Ultrasonic vibration may cause deterioration and destruction of the components.
Please avoid ultrasonic cleaning

8-3 We recommend storing products at +15°C to +35°C and 25% R.H to 75% R.H 8-

4 ESD Level : Class2(2000V ~ 4000V)

8-5 MSL LEVEL 1 (JEDEC J-STD-020C)

ITEM	Floor Life		Soak Requirements	
	Time	Conditions	Time	Conditions
1	Unlimited	=< 30°C/85%RH	165+5/-0	=< 85°C/85%RH

8-6 Unless adequate negative resistance is allocated in the oscillation circuit, start up time of oscillation may be increased, or no oscillation may occur. In order to avoid this, please provide enough negative resistance in the circuit design.

© How to check the negative resistance

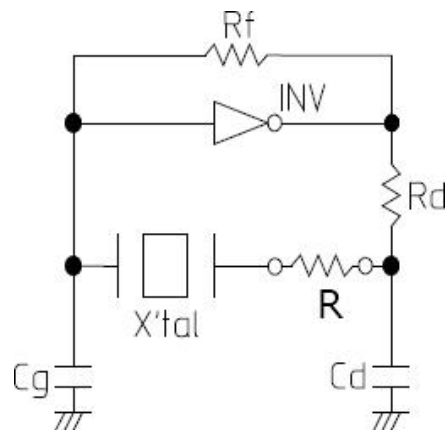

- (1) Connect the resistor (R) to the circuit in series with the crystal resonator.
- (2) Adjust R so that oscillation can start (or stop).
- (3) Measure R when oscillation just start (or stop) in above (2).
- (4) Get the negative resistance
 $-R = R + CI$ value
- (5) Recommended -R
 $[-R] > CI \times 5$

9. Packing

9.1 Reel, carrier tape material

item	Main Material
Cover Tape	PE (Polyester film)
Carrier Tape	PC (Poly Carbonate +Carbon) or (Clear Poly Carbonate)
Reel	PS (Poly Styrene)

9.2 inner Box :1 reel/inner box and 2,000 pcs or 3,000 pcs /1 reel.

9.3 Outer Box : 10 inner boxes/Outer Box

Max 30,000 pcs are packed in a 1 outer box

9.4 Reel and Carrier tape dimensions(unit : mm)

■ Carrier tape

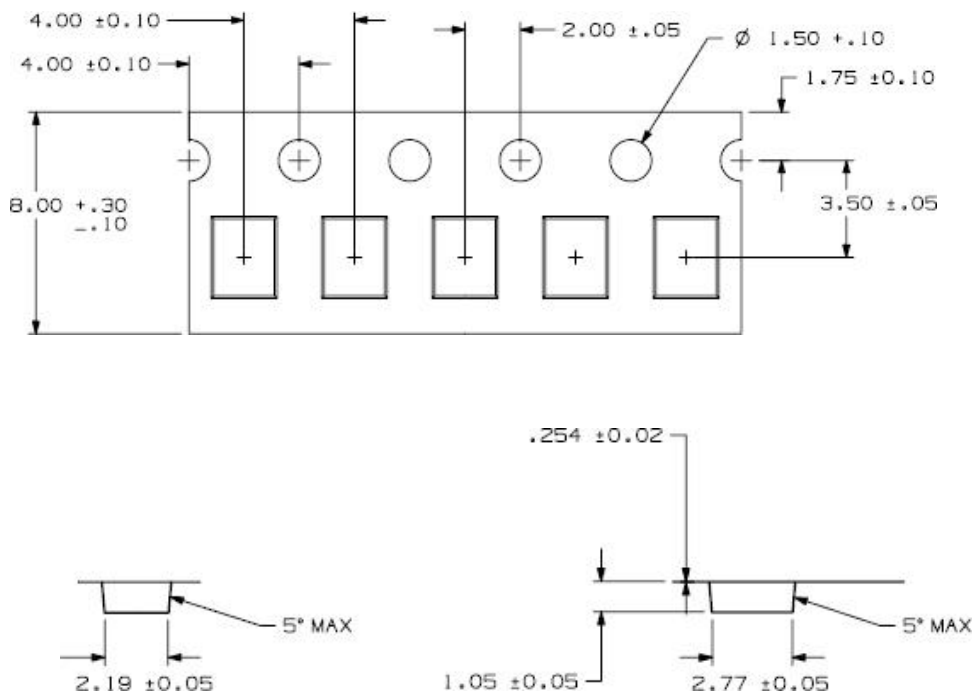

*Heating press cover tape

9.5 Reel Dimensions (unit : mm)

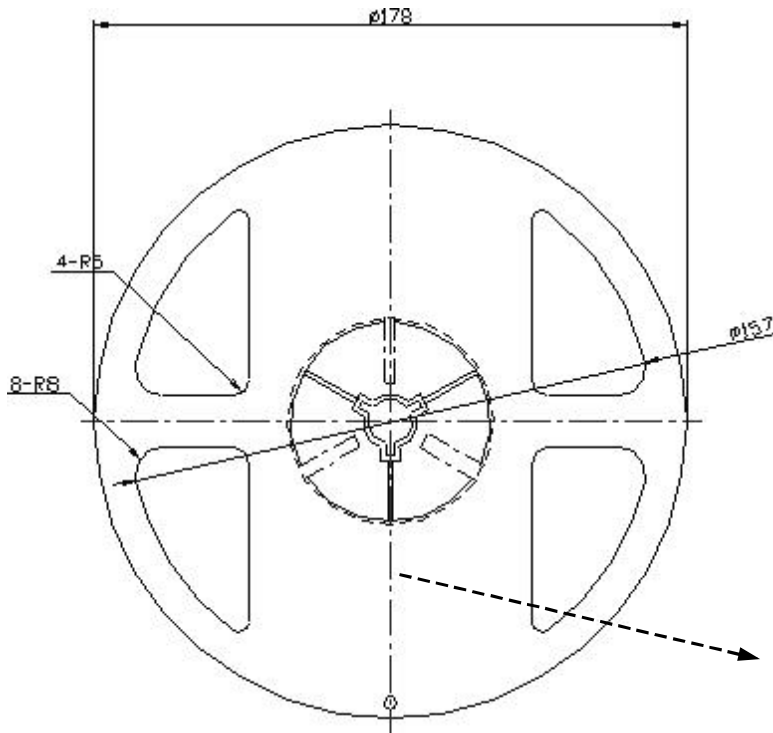
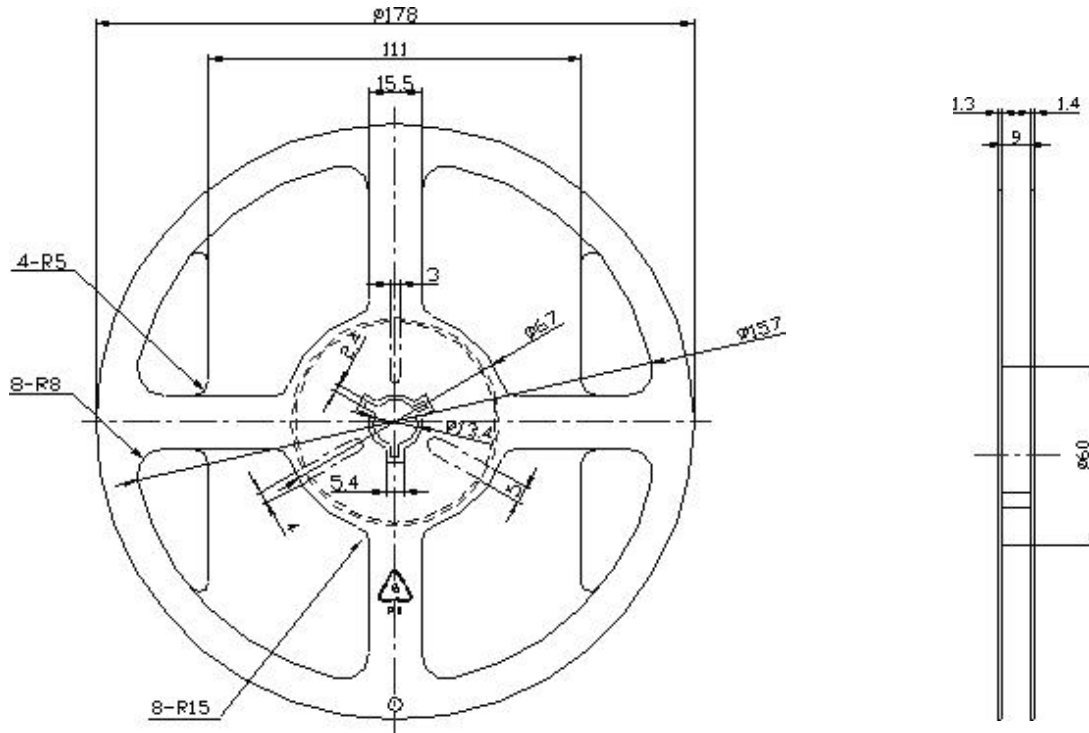

9.6 Tape and Reel

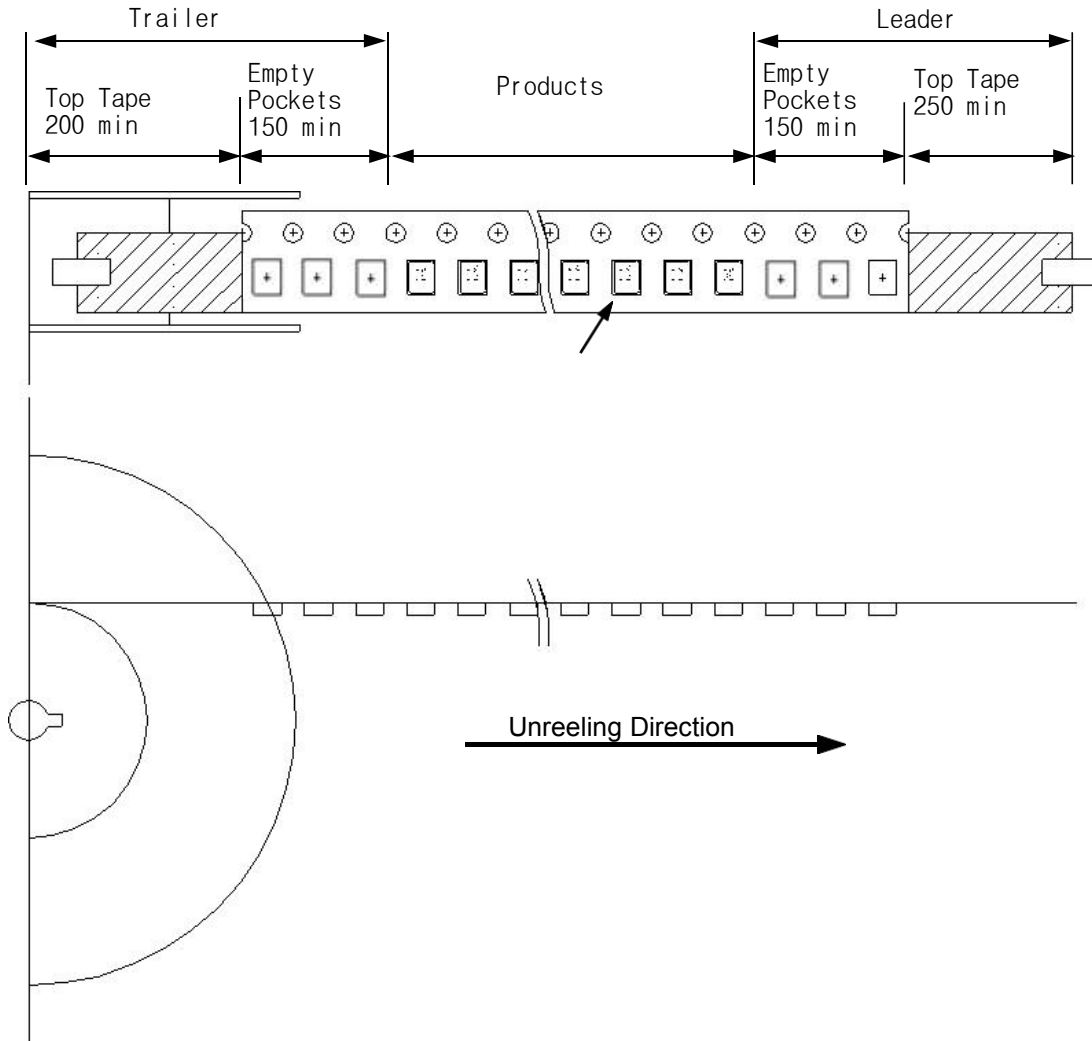

9.7 Inner, outer box Dimensions (unit : mm)

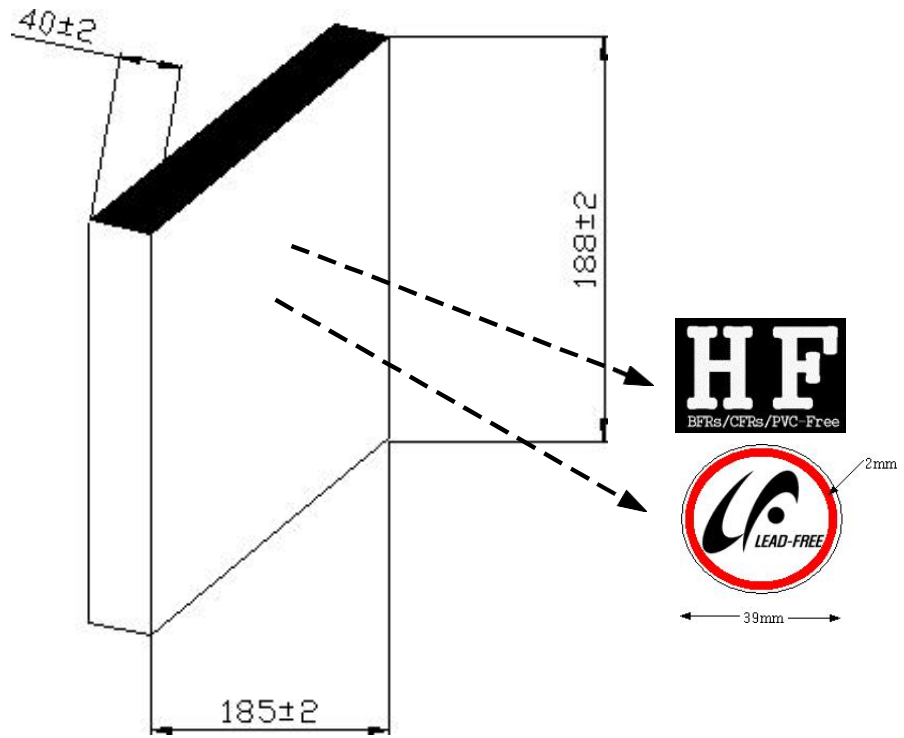

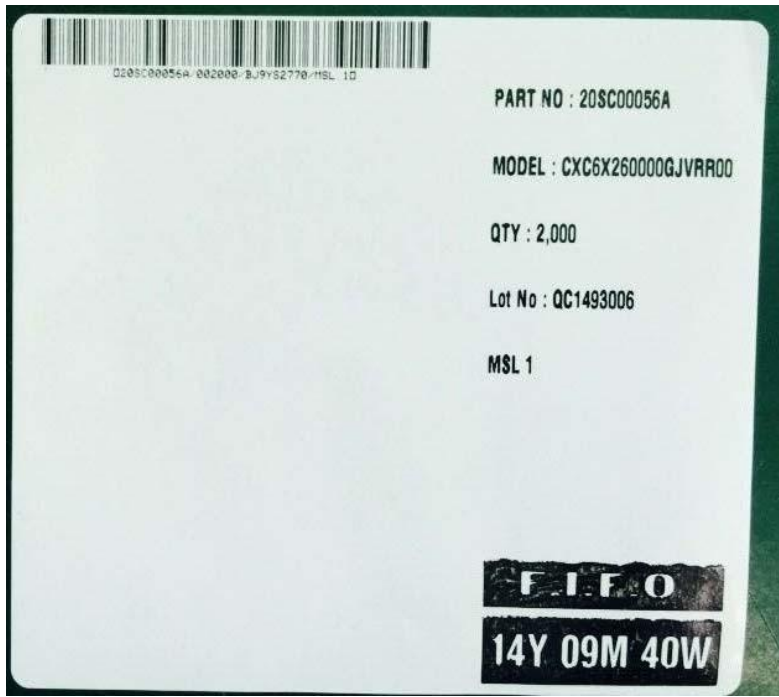
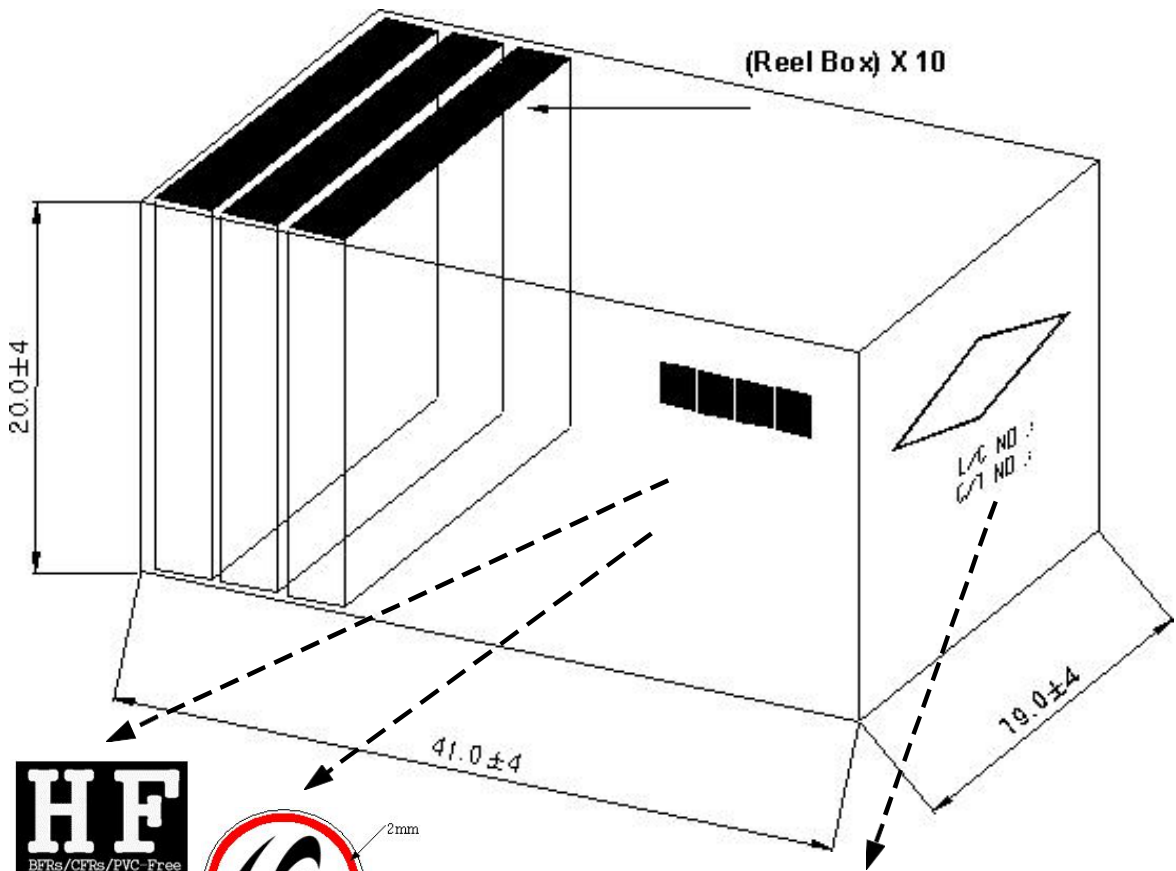



KEYUANXIN TECHNOLOGY GO.,LTD

浏览网址：www.szkyx.cn