



深圳市科源信科技有限公司
Shenzhen KeYuanXin Technology CO., LTD

产品规格书

SPECIFICATION FOR APPROVAL

深圳市福田区振华路 118 号华丽装饰一栋西座 306A
306A Block West Building 1, Huali Decoration
NO. 118 Zhenhua Road Futian District Shenzhen
电话 TEL: 4008-735-535 传真 FAX: 0755-23616323



Product Name:

Crystal

Product Type:

SMD 3225

Nominal Freq:

16.0000MHz

ProvideBrand:

PARTRON

P/N:

CXC3X160000GHVRN00

Customer P/N:

Approved By Customer

Signature:

Date:

Contents

1. Revision History	- - - 3
2. Electrical characteristics	- - - 4
3. Mechanical characteristics	- - - 6
4. A Primary test result	- - - 7
5. Reliability test	- - - 8
6. Construction	- - - 9
7. Notices	- - - 10
8. Packing	- - - 11

1. Revision History

Rev.	Date	Rev. page	Revision Content and Reason	Remark
V1.0	'13.06.12	All Page	First-edition	
V1.1	'15.01.19	Page 11 ~ 14	Reel & Box size change Before : 7" reel & box (Total : 20,000ea) After : 13" reel & box (Total : 100,000ea)	J.S.B

1. Scope

This specification is for SMD crystal units

2. Electrical Characteristics

No.	Item	Symbol	Content
2.1	Frequency	fo	16.0000 MHz
2.2	Frequency Tolerance CTQ	$\Delta f/fo$	± 10 ppm (@+25°C $\pm 2^\circ\text{C}$)
2.3	Temperature range	Storage	T _{STG} -40 to 85°C
		Operating	T _{OPR} -20 to 70°C
2.4	Frequency stability	$\Delta f/fo$	± 10 ppm (-20°C to +70°C, Ref. @+25°C $\pm 2^\circ\text{C}$)
2.5	Drive level	DL	100 uW max.
2.6	Equivalent series resistance	R1	80Ω max.
2.7	Oscillation mode	O/T	Fundamental
2.8	Shunt capacitance	CO	3 pF max.
2.9	Motional capacitance	C1	10 fF max.
2.10	Load capacitance	C _L	9 pF
2.11	Aging	fa	± 3 ppm/3year max. (@+25°C $\pm 2^\circ\text{C}$)
2.12	Insulation resistance	IR	500 MΩ min @ 100VDC

[REMARK]

2-1 Crystal Equivalent Circuit and Application Circuit

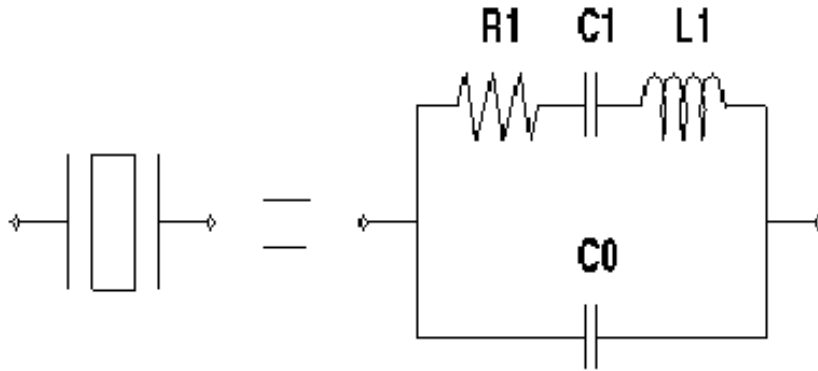

[Crystal and equivalent circuit]

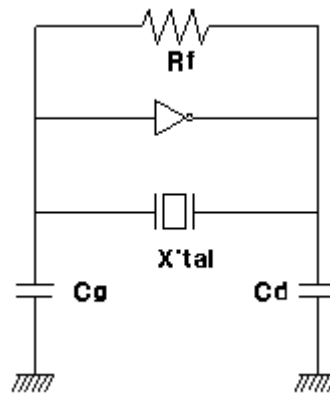

[Application circuit for oscillation]

3. Mechanical characteristics

3-1 Outline Dimensions and Pin connections

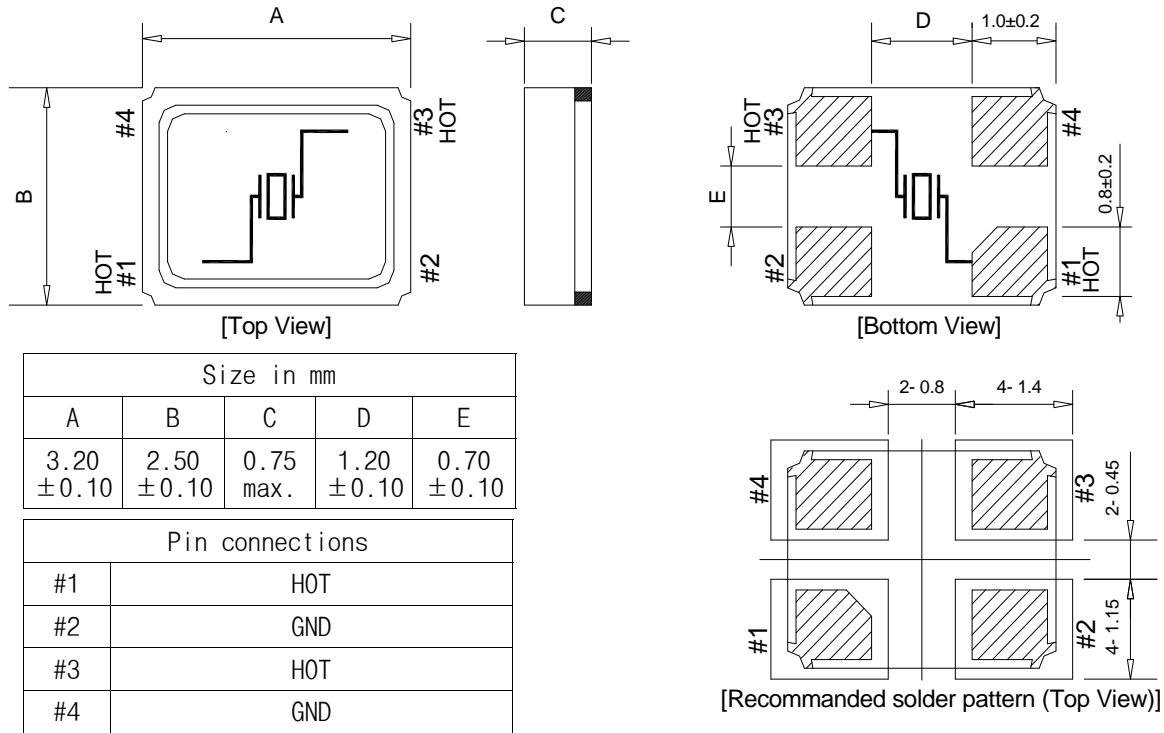

3-2 Marking and LOT No

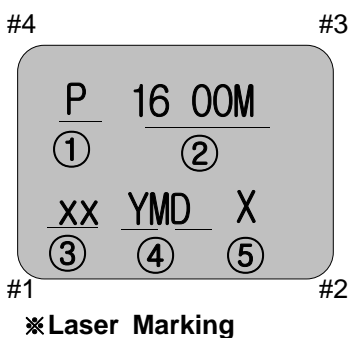

ITEM	MARKING	REMARK
①	P	Partron logo
②	16 00M	Frequency: 16.0000MHz
③	XX	CRYSTAL CL
④	YMD	Y : the last 1 digit of year M : 1 digit of month (Jan to Sept; 1 to 9, Oct; A, Nov B, Dec; C) D : 1 digit of day 1 to 9, A to V (A=10, V=31) EX) 769 = 2007.06.09, 8AS = 2008.10.28
⑤	X	Internal code

4. A Primary test result

Electrical Characteristics Testing Data

5. Reliability test

5.1 Environment Test

Contents	Condition	Remark
High temperature Storage	+125°C ±5°C, 240 hr	*Testing is complete, leave at room temperature for 24 hours, and Measure. (25°C ±5°C)
Low temperature Storage	-55°C ±5°C, 240 hr	
High temperature High humidity Storage	+85°C ±5°C, RH=85%, 96 hr	
PCT	+121°C ±5°C, RH=100%, 24hr	

5.2 Thermal shock , Reflow Test

Contents	Condition	Remark
Thermal shock	-40°C ±5°C, +85°C ±5°C, 30 min, 32 cycle	*Testing is complete, leave at room temperature for 24 hours, and Measure. (25°C ±5°C)
REFLOW	Pre Heating 200±5°C , 30~60 sec Peak Heating 260°C ±5°C , 30sec Max	

5.3 Mechanical Test

Contents	Condition	Remark
Vibration	Frequency : 10~500Hz, 10 ×9.8m/s ² (G) Sweep time 15min ,X.Y.Z each 5 times	*Testing is complete, leave at room temperature for 24 hours, and Measure. (25°C ±5°C)
Drop test	12 times falling at a 150cm height (falling with jig)	
Leakage	Helium leak detector	1x10 ⁻⁹ Pa.m ³ Max.

5.4 Soldering Condition

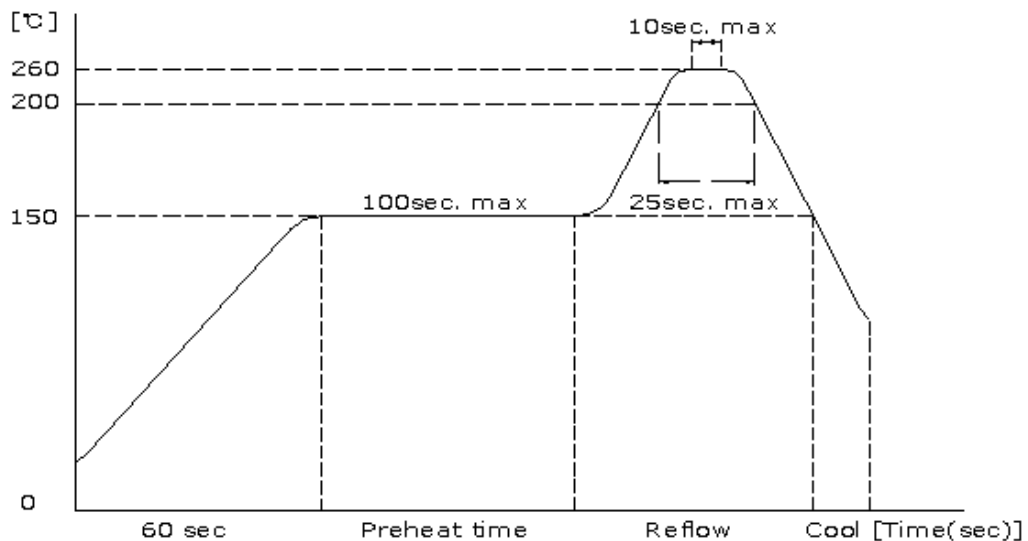

※ The maximum temperature guarantees to the 260°C±5°C (10sec. Max.)

6. Construction

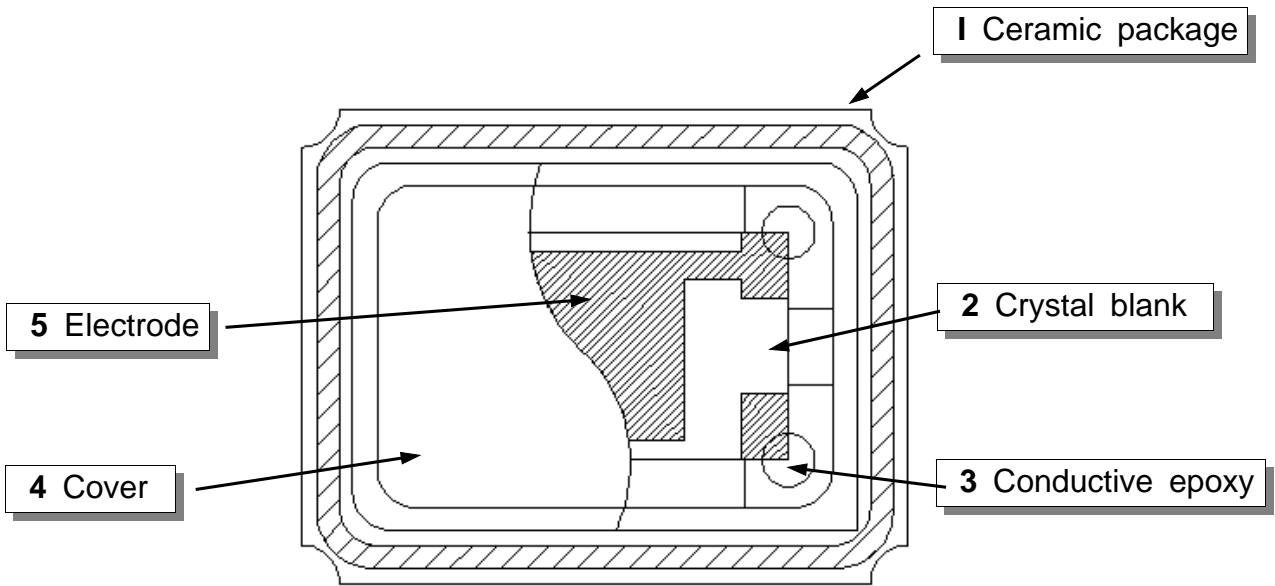

No	item
1	Ceramic package
2	Crystal blank
3	Conductive Epoxy
4	Lid(Cover)
5	Electrode

7. Notices

7-1 Max. two(2) times reflow is allowed.

Once miss soldering is happen, hand work soldering by soldering iron is recommended.
(+400°C x within 5 sec)

7-2 Ultrasonic vibration may cause deterioration and destruction of the components.

Please avoid ultrasonic cleaning

7-3 We recommend storing products at +15°C to +35°C and 25% R.H to 75% R.H

7-4 ESD Level : Class2(2000V ~ 4000V)

7-5 MSL LEVEL 1 (JEDEC J-STD-020C)

ITEM	Floor Life		Soak Requirements	
	Time	Conditions	Time	Conditions
1	Unlimited	=< 30°C/85%RH	165+5/-0	=< 85°C/85%RH

7-6 Unless adequate negative resistance is allocated in the oscillation circuit, start up time of oscillation may be increased, or no oscillation may occur. In order to avoid this, please provide enough negative resistance in the circuit design.

◎ How to check the negative resistance

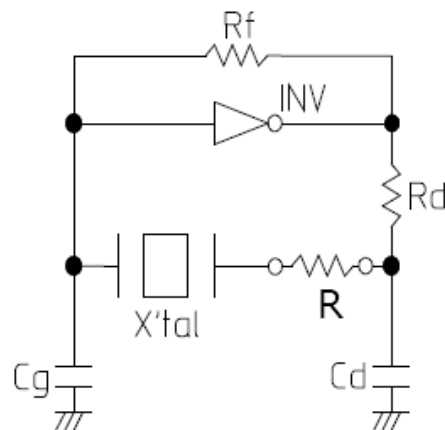

- (1) Connect the resistor (R) to the circuit in series with the crystal resonator.
- (2) Adjust R so that oscillation can start (or stop).
- (3) Measure R when oscillation just start (or stop) in above (2).
- (4) Get the negative resistance
 $-R = R + CI \text{ value}$
- (5) Recommended -R
 $[-R] > CI \times 5$

8. Packing

8.1 Reel, carrier tape material

item	Main Material
Cover Tape	PE (Polyester film)
Carrier Tape	PC (Poly Carbonate +Carbon) or (Clear Poly Carbonate)
Reel	PS (Poly Styrene)

8.2 inner Box

Reel size	Quantity
13"	(5,000 or 10,000 pcs) x 2set

8.3 Outer Box

Inner Box	Quantity
3EA	60,000 pcs
5EA	100,000 pcs

8.4 Reel and Carrier tape dimensions(unit : mm)

Carrier tape

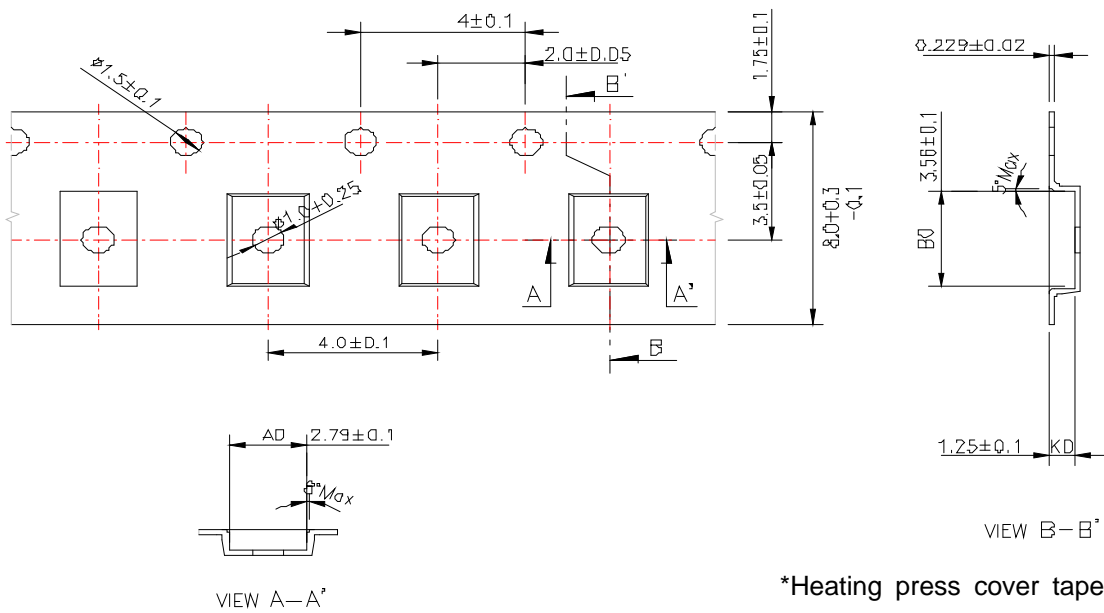

■ Reel

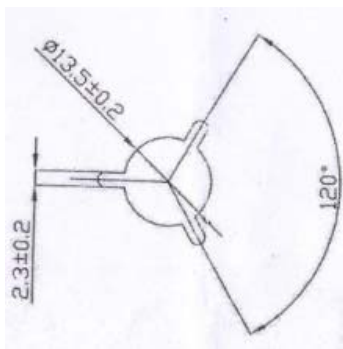
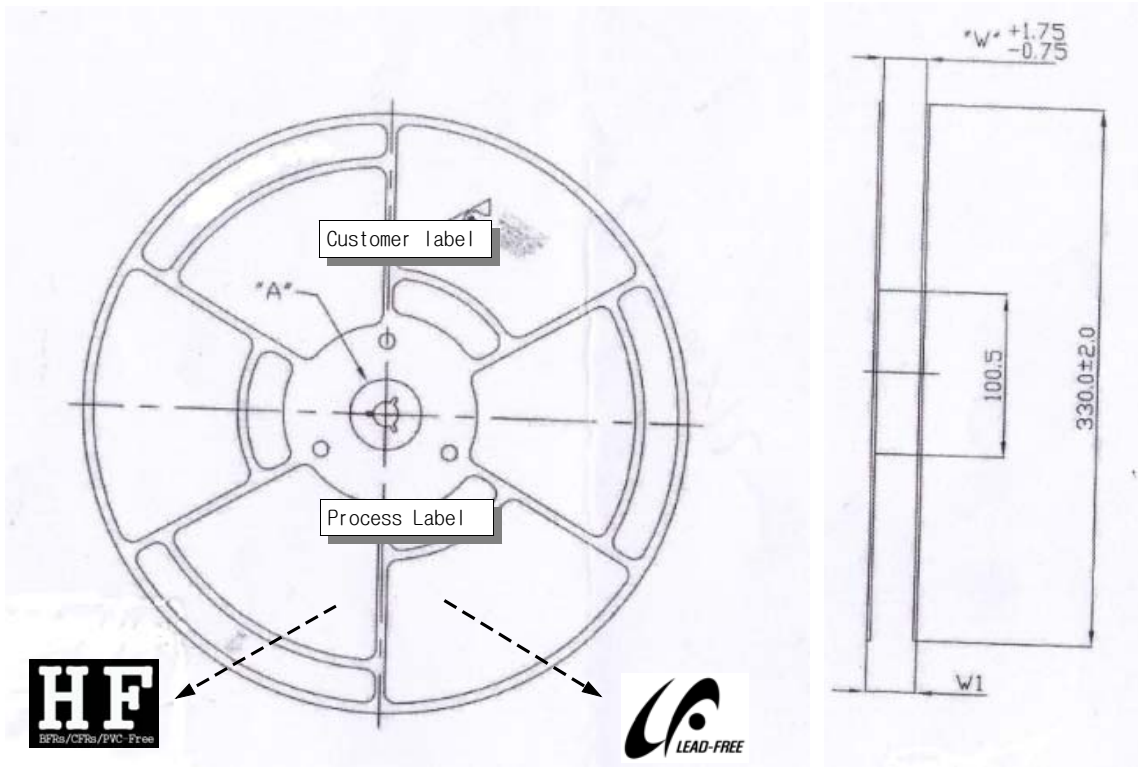

	W	W1
Size	9.5mm	11.5mm

8.5 Tape and Reel

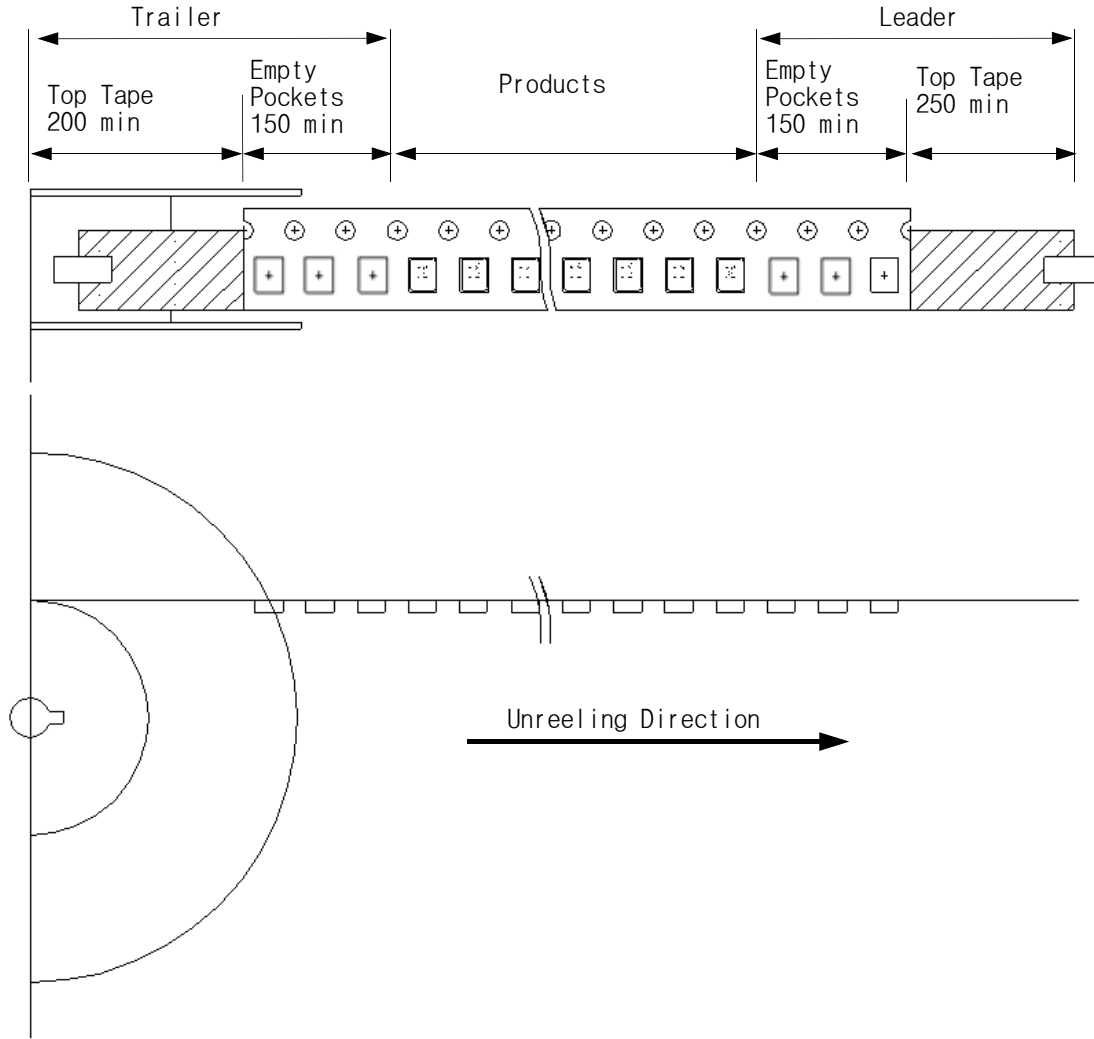

8.6 Inner, outer box Dimensions (unit : mm)

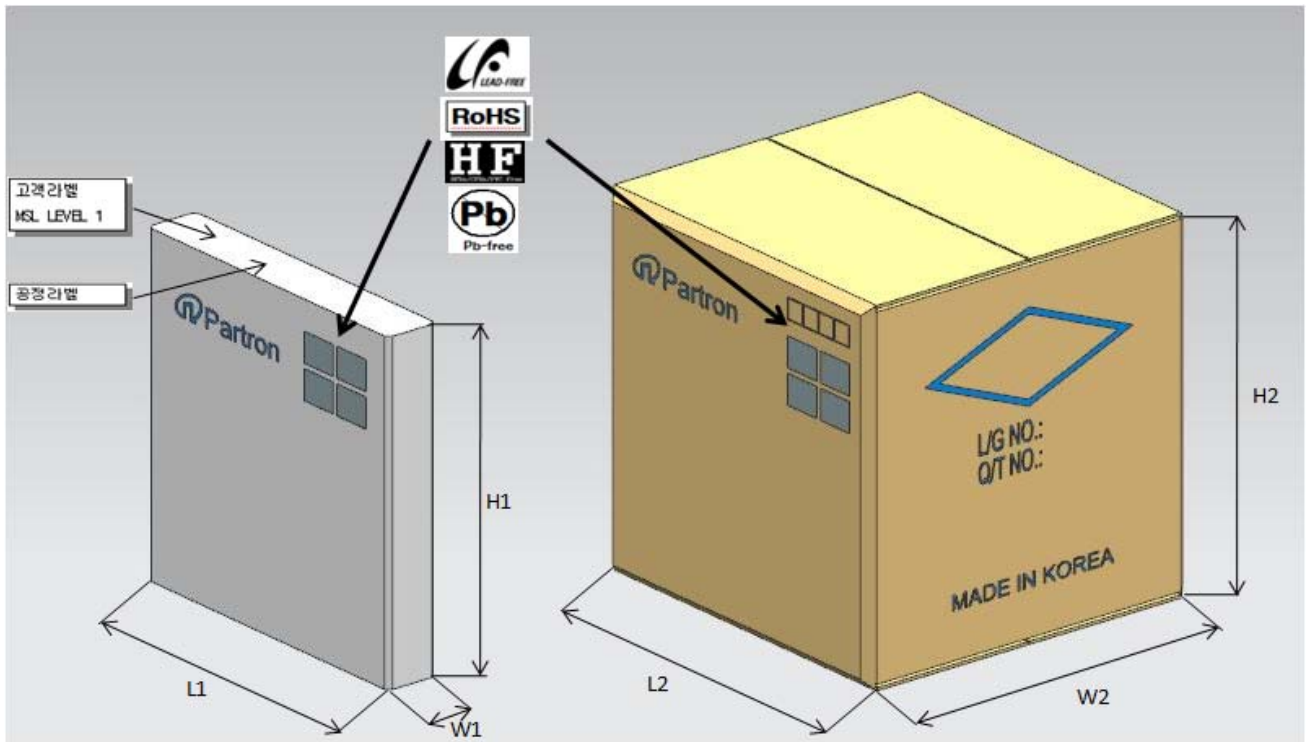

Item	Inner Box		Outer Box		
	Mark	Dimension	Mark	Dimension (Type #1)	Dimension (Type #2)
Size	L1	330mm	L2	355mm	355mm
	W1	54mm	W2	200mm	355mm
	H1	330mm	H2	355mm	355mm
Material	Corrugated Cardboard		Corrugated Cardboard		
Quantity	20,000 EA (Reel * 2set)			60,000 EA (Inner Box * 3set)	100,000 EA (Inner Box * 5set)



KEYUANXIN TECHNOLOGY GO.,LTD

浏览网址：www.szkyx.cn